

P-BE stainless steel filter housing

Filter housing for the aeration and de-aeration of sterile storage tanks or containers for transport.

Product description:

Filters for the aeration, de-aeration and venting of product series P-BE are used to ensure 100% sterility in the storage of pharmaceutical products, containers of DI water, food, chemicals, and/or the de-aeration of fermenters. The user-friendly two-piece housing has a splash protection to prevent liquids coming in contact with the filter medium and damage it.

Numerous sizes of housings allow to adopt the filter exactly to the respective requirements. In this product series 12 different housing sizes are available for volume flows of 4.5 to 2.010 m³/h at 1 bar (2,6 to 1.180 cfm at 14,7 psi). Due to the ultrafilter modular design different filter elements can be used in this housing according to the application. Apart from sterile depth filters there is a choice between hydrophobic polypropylene or Teflon* membrane filters with a retention rate down to 0.01 µm.



Technical data

Materials:

Filter housing:	stainless steel 1.4301 (304) optional 1.4404 (316L)
-----------------	--

Surface finish:

finished on the inside and on the outside
polished

Connection types:

Milkipipe DIN 11851
(standard at 0006–0192)
DIN or ANSI flange
(standard from 0432; optional up to
0192)
Clamp (on request)

Maximum operating temperature:

200°C

* Teflon is a registered trademark of the DuPont company

Vent filter P-BE 0006-0192 with milkpipe connection DIN 11851

Pos.	Piece	Description
5	3	socket head screw
4	1	filter element
3	3	lone socket
2	1	lower housing bowl
1	1	upper housing bowl

Max. operating temperature:	200°C
Material:	
Housing:	1.4301
Attaching parts:	1.4301
Surface finish:	finished inside, polished outside

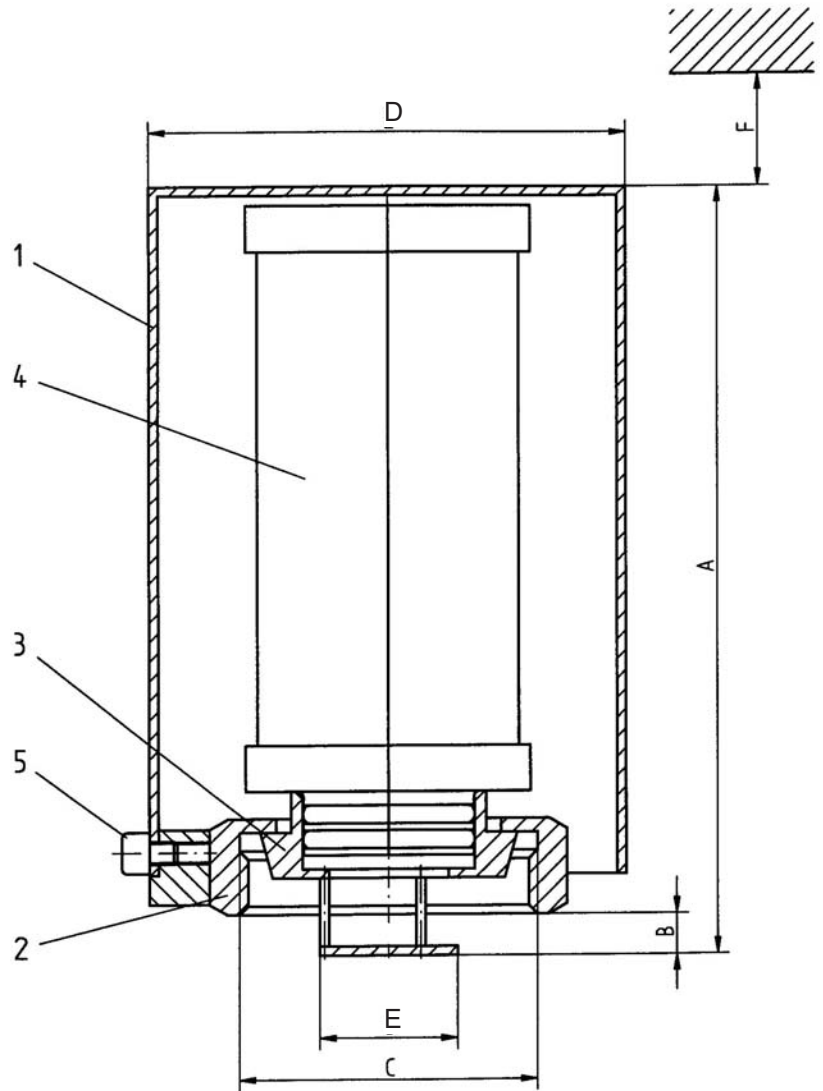

Size	Weight* (kg)	A mm	B mm	C DIN 11851	ø D mm	ø E mm	F mm	Element
0006	1,5	110	9	DN 32/ Rd 58 x 1/6	85,0 x 2	24	100	03/10
0027	2,2	168	9	DN 40/ Rd 65 x 1/6	104,0 x 2	30	155	05/25
0032	2,4	186	9	DN 50/ Rd 78 x 1/6	114,3 x 2	42	155	05/30
0072	3,3	312	9	DN 50/ Rd 78 x 1/6	114,3 x 2	42	280	10/30
0144	9,2	550	8	DN 80/ Rd 110 x 1/4	154,0 x 2	70	580	20/30
0192	11,6	805	8	DN 80/ Rd 110 x 1/4	154,0 x 2	70	850	30/30

* without filter element

Vent filter P-BE 0432-1920 with flange connection

Pos.	Description
5	filter element
4	anchor bolt
3	lifting eye nut
2	lower housing bowl
1	upper housing bowl

Max. operating temperature:	200°C
Material:	
Housing:	1.4301
Attaching parts:	1.4301
Surface finish:	finished inside, polished outside

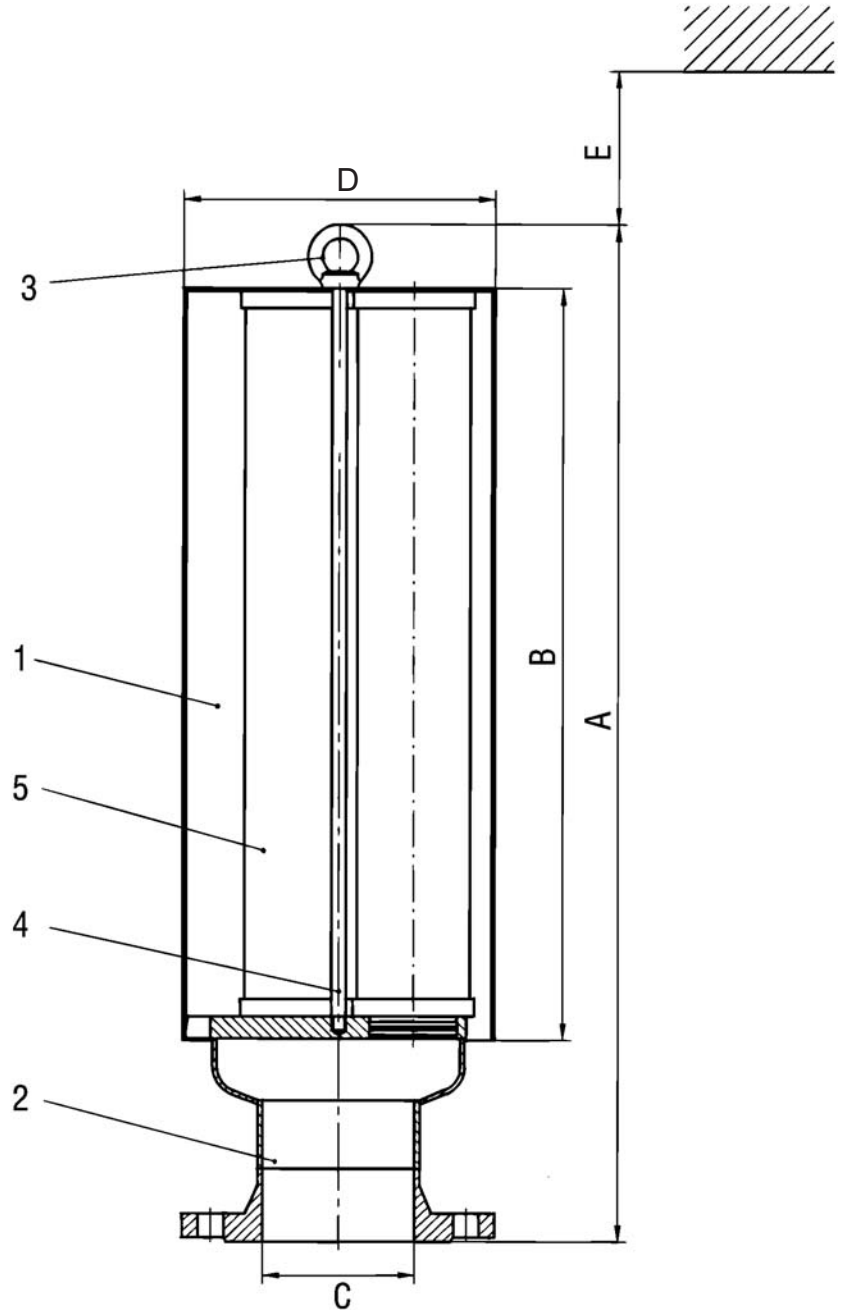

Size	Weight* (kg)	A mm	B mm	C DIN EN 1092-1, B1	ø D mm	E mm	Element
0432	14.5	670	530	DN 100	219,1	580	3 x 20/30
0576	17.5	925	780	DN 100	219,1	850	3 x 30/30
0768	30	950	780	DN 150	273	850	4 x 30/30
1152	30	950	780	DN 150	323,9	850	6 x 30/30
1536	43	960	780	DN 200	406,4	850	8 x 30/30
1920	43	960	780	DN 200	406,4	850	10 x 30/30

* without filter element

GB-2020-01-01